

THIS DRAWING IS UNPUBLISHED. RELEASED FOR PUBLICATION
 © COPYRIGHT BY TYCO ELECTRONICS CORPORATION. ALL RIGHTS RESERVED.

LOC	DIST	REVISIONS					
G	14	P	LTR	DESCRIPTION	DATE	DWN	APVD
		G2		REV PER ECR 08-015270	16JUN08	JR	TM

AMP WIRE RANGE	Listed	LR7189 Certified
12-10 AWG SOLID OR STRANDED	12-10 AWG SOLID OR STRANDED	12-10 AWG SOLID OR STRANDED

- 1 STAMP 8S AMP 12-10* APPROX AS SHOWN
- 2 WIRE INSULATION DIA .150-.250
- 3 TONGUE MATERIAL THICKNESS .039±.002
- 4 MATERIAL: BODY - PHOS BRONZE PER ASTM B103
PLASTIC SLEEVE - NYLON, COLOR-YELLOW
METAL SLEEVE - COPPER PER ASTM B152
- 5 FINISH: BODY - TIN PLATE PER ASTM B545
METAL SLEEVE - TIN PLATE PER ASTM B545
- 6 DIMENSION APPLIES FROM EDGE OF METAL WIRE BARREL TO CENTER OF STUD.

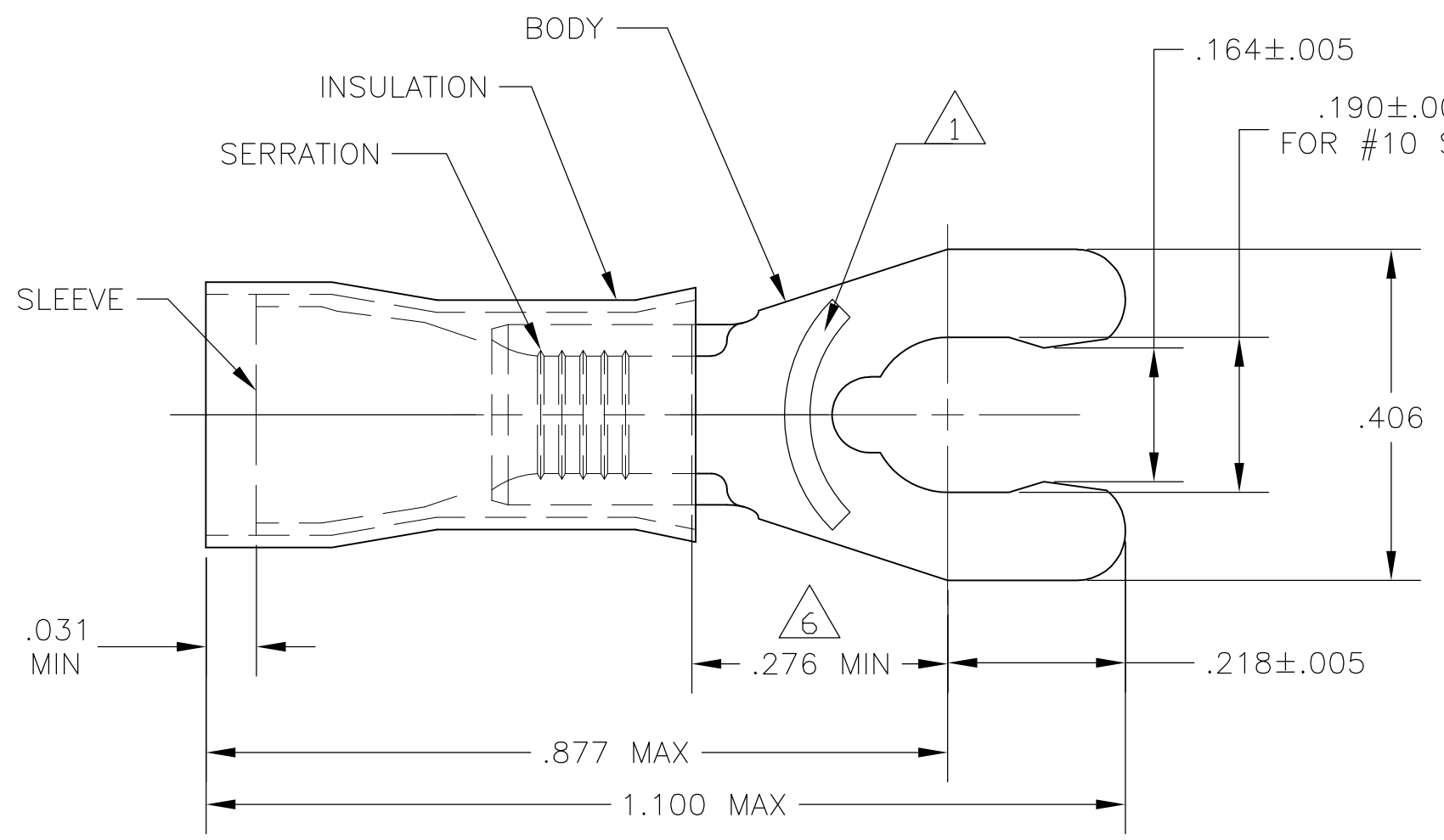

100	LOOSE PC, BOX	8-52943-1
1	ON TAPE	52943-1
1	LOOSE PIECE	52943
QTY	PACKAGE TYPE	PART NO

THIS DRAWING IS A CONTROLLED DOCUMENT.		DWN jr_ruth 20MAR07	Tyco Electronics Corporation Harrisburg, PA 17105-3608													
DIMENSIONS: INCHES		CHK T MICHELUTTI 20MAR07														
TOLERANCES UNLESS OTHERWISE SPECIFIED:		APVD T MICHELUTTI 20MAR07	NAME TERMINAL, SPRING SPADE, STUB, PIDG WIRE SIZE: 12-10													
<table border="0"> <tr><td>0 PLC</td><td>± -</td></tr> <tr><td>1 PLC</td><td>± -</td></tr> <tr><td>2 PLC</td><td>± -</td></tr> <tr><td>3 PLC</td><td>± .008</td></tr> <tr><td>4 PLC</td><td>± -</td></tr> <tr><td>ANGLES</td><td>± 5°</td></tr> </table>		0 PLC	± -	1 PLC	± -	2 PLC	± -	3 PLC	± .008	4 PLC	± -	ANGLES	± 5°	PRODUCT SPEC -	SIZE A3	
0 PLC	± -															
1 PLC	± -															
2 PLC	± -															
3 PLC	± .008															
4 PLC	± -															
ANGLES	± 5°															
MATERIAL - 4		APPLICATION SPEC -	CAGE CODE 00779	DRAWING NO G-52943												
FINISH - 5		WEIGHT -	RESTRICTED TO -													
CUSTOMER DRAWING			SCALE 5:1	SHEET 1 OF 1												
			REV G2													